

Specifications

Demolition Hammer

Blows per minute 1,100 – 2,650
 Continuous rating
 Input 1,100 W
 Overall length 454 mm (17-7/8")
 Net weight 4.7 kg (10.4 lbs)
 Power supply cord 5.0 m (16.4 ft.)

Specifications may differ from country to country.

Dimension

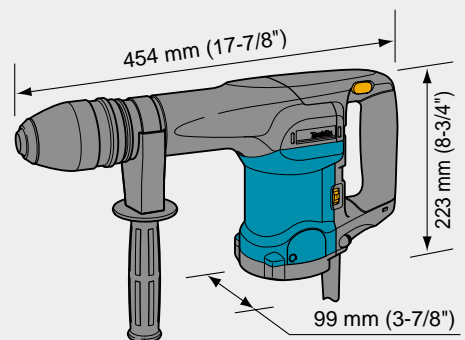

Standard equipment

Demolition Hammer

	Part No.		Part No.
Bar formed side handle	152554-4	Plastic carrying case	824708-0
Bit grease	181573-3		

Note: The standard equipments may differ from country to country.

Optional Accessories

Demolition Hammer

Bull point (For demolishing concrete)		Cold chisel (For chipping, edging, channeling and breaking away larger chunks of concrete)		Scaling chisel (A wide chisel for chipping away scale of dried concrete spatter)		Clay spade (For digging in clay, scale etc.)	
L (mm)	Part No.	WxL (mm)	Part No.	WxL (mm)	Part No.	WxL (mm)	Part No.
280	A-80787	25 x 280	A-80802	50 x 300	A-80830	105 x 400	A-17653
400	A-80793	25 x 400	A-80818	50 x 400	A-80824		
600	A-87476	24 x 600	A-87482				
Bushing tool (For concrete surface removal)		Rammer (For tamping operations)		D formed side handle			
* Use with shank (A-19897)		* Use with shank (A-19897)		Part No.			
A x B (mm)	Part No.	Dia. (mm)	Part No.	134909-5			
67 x 67	A-19881	140	A-19875				



A world's leading manufacturer of power tools

- SDS-Max drive
- Double Insulation
- Variable Speed
- Soft Start
- Electronic Speed Control
- Carrying Case

Demolition Hammer

Model HM0860C



NEW



A world's leading manufacturer of power tools

*Strong power flows out of the gracefully streamlined design.
You will surely be amazed to find the beast in the beauty.*



- 1. One action slide chuck
Rapid and easy replacement of bit.
- 2. 12 angles setting of hammer bit
- 3. Easy to hold the machine with ergonomically designed barrel
- 4. Plastic cover on the housing
Protecting operator completely from electric shock.
- 5. Slide action switch
- 6. Pre-setting dial for speed control
- 7. Easy carbon brush change

- 8. Durable cord guard

- 10. Soft grip for comfortable work

9. Warning lamp

- Warning lamp indicating when there is switch failure, or cord break.
- Service reminder light telling you to replace carbon brush.

Electronic features for

- Soft start
- Keeping the pre-set speed constantly.

Performance Data

Comparison of working speed with percussion drill mode

Material : concrete with compressive strength, 35N/mm²
Chipping direction : horizontal as illustrated right

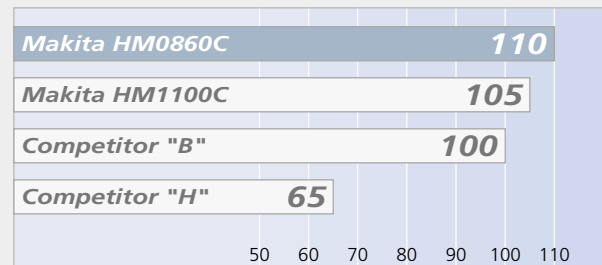

- Numbers in chart are relative values when setting "B's" capacity as 100.
- It may differ under some conditions.

Net weight

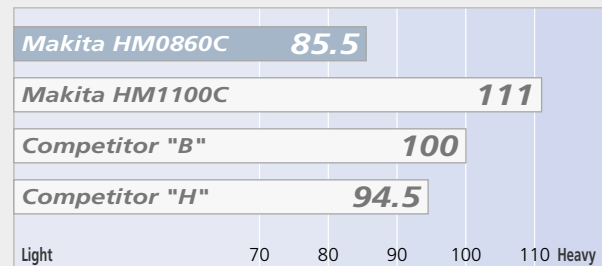

- Numbers in chart are relative values when setting "B's" net weight as 100.



HM0860C

Demolition Hammer

- SDS max bit can be used.
- Very light, Only 4.7 kg (10.4 lbs) in weight.

