

Standard equipment

Demolition Hammer

For model HP1620 / F, HP1621 / F		For model HP1620 / F	
	Part No.		Part No.
Side handle	152489-9	Chuck key	763440-0
Depth gauge	324219-0		
Plastic carrying case (HP1620K / FK, HP1621K / FK only)	824478-1		

Note: The standard equipments may differ from country to country.

Optional Accessories

Demolition Hammer

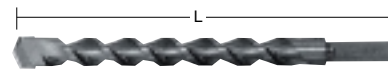
Tungsten carbide-tipped bit			Bit diameter (mm)	L (mm)	Part No.
			8.5	100	791008-2
			8.5	180	711026-4
			9.5	120	711058-1
			10.5	120	711059-9
			11.0	120	791009-0
			12.5	120	711060-4
			14.0	150	791029-4
			14.0	180	711027-2
			14.0	300	711028-0
			16.0	220	791036-7

Bit diameter (mm)	L (mm)	Part No.
5.0	70	791027-8
6.5	80	791092-7
7.5	90	791028-6
8.0	120	711057-3



A world's leading manufacturer of power tools



Hammer Drills 16 mm (5/8")

HP1620 / HP1620F
HP1621 / HP1621F



Makita Corporation

3-11-8, Sumiyoshi-cho, Anjo, Aichi 446-8502, Japan

PRINTED IN JAPAN Z23103-2 2003-9

NEW



A world's leading manufacturer of power tools

Highest Performance, long life Hammer Drills in its class!

Comparison of working speed with percussion drill mode

Material : Mortar
Pressure loaded to the product : 150 N

equipped bit : ø6.5 mm (1/4") 70 80 90 100 110 120 130 140

Makita HP1620 (F) / HP1621 (F) 115

Makita HP1500 100

Competitor "B" 100

Competitor "M" 100

equipped bit : ø8 mm (5/16") 70 80 90 100 110 120 130 140

Makita HP1620 (F) / HP1621 (F) 120

Makita HP1500 100

Competitor "B" 105

Competitor "M" 100

equipped bit : ø10.5 mm (13/32") 70 80 90 100 110 120 130 140

Makita HP1620 (F) / HP1621 (F) 145

Makita HP1500 100

Competitor "B" 105

Competitor "M" 95

equipped bit : ø16 mm (5/8") 70 80 90 100 110 120 130 140

Makita HP1620 (F) / HP1621 (F) 140

Makita HP1500 100

Competitor "B" 90

Competitor "M" 75

Comparison of working speed in wood with drill mode

Material : Douglas fir

equipped bit : ø30 mm (1-3/16") Auger bit 90 100 110 120 130 140

Makita HP1620 (F) / HP1621 (F) 120

Makita HP1500 100

Competitor "B" 100

Competitor "M" 100

- Numbers in chart below are relative values when setting "HP1500's" capacity as 100.
- It may differ under some conditions.



Photo : Model HP1621F

16 mm (5/8") Hammer Drills

HP1620 / HP1620F / HP1621 / HP1621F

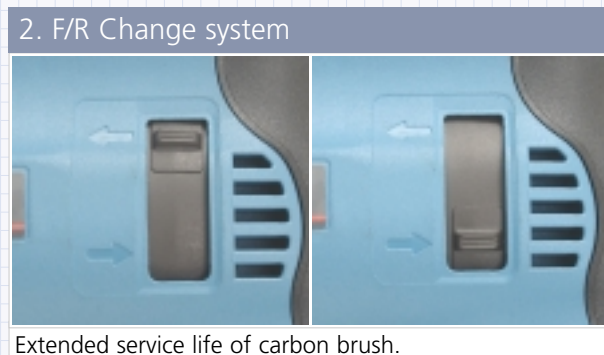
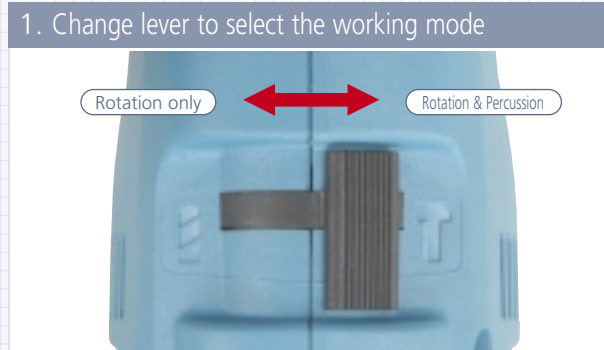

Extended service life of carbon brush.

1. Change lever to select the working mode
3. In-Line designed handle for efficient transmission of pressure
4. Lock ON button for continuous operation
5. Palm fitting soft grip for comfortable operation
6. LED Job Light (only for HP1620F and HP1621F)
7. Big trigger switch

Max. capacities	
Concrete	16 mm (5/8")
Steel	13 mm (1/2")
Wood	30 mm (1-3/16")
Continuous rating	
Input	650 W
No load speed	0 - 2,800 min ⁻¹ (rpm)
Blows per minute	0 - 44,800
Overall length	303 mm (11-7/8")
Net weight	1.7 kg (3.7 lbs)
Power supply cord	2.0 m (6.6 ft.)
Specifications may differ from country to country.	

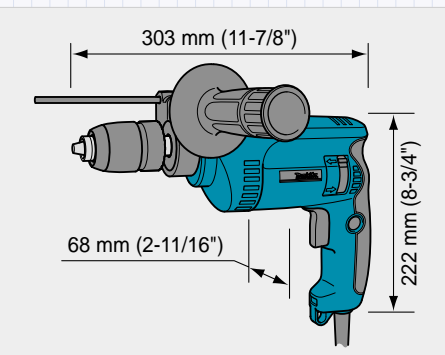

Model	LED Job Light	Keyless drill chuck
HP1620	No	No
HP1620F	Yes	No
HP1621	No	Yes
HP1621F	Yes	Yes