



Rotary Hammer

HR4041C 40mm (1-9/16")

Satisfy Professional's Needs



Spline Shank Type
for rotary hammering



3/4" Hex Shank Type
for demolition hammering

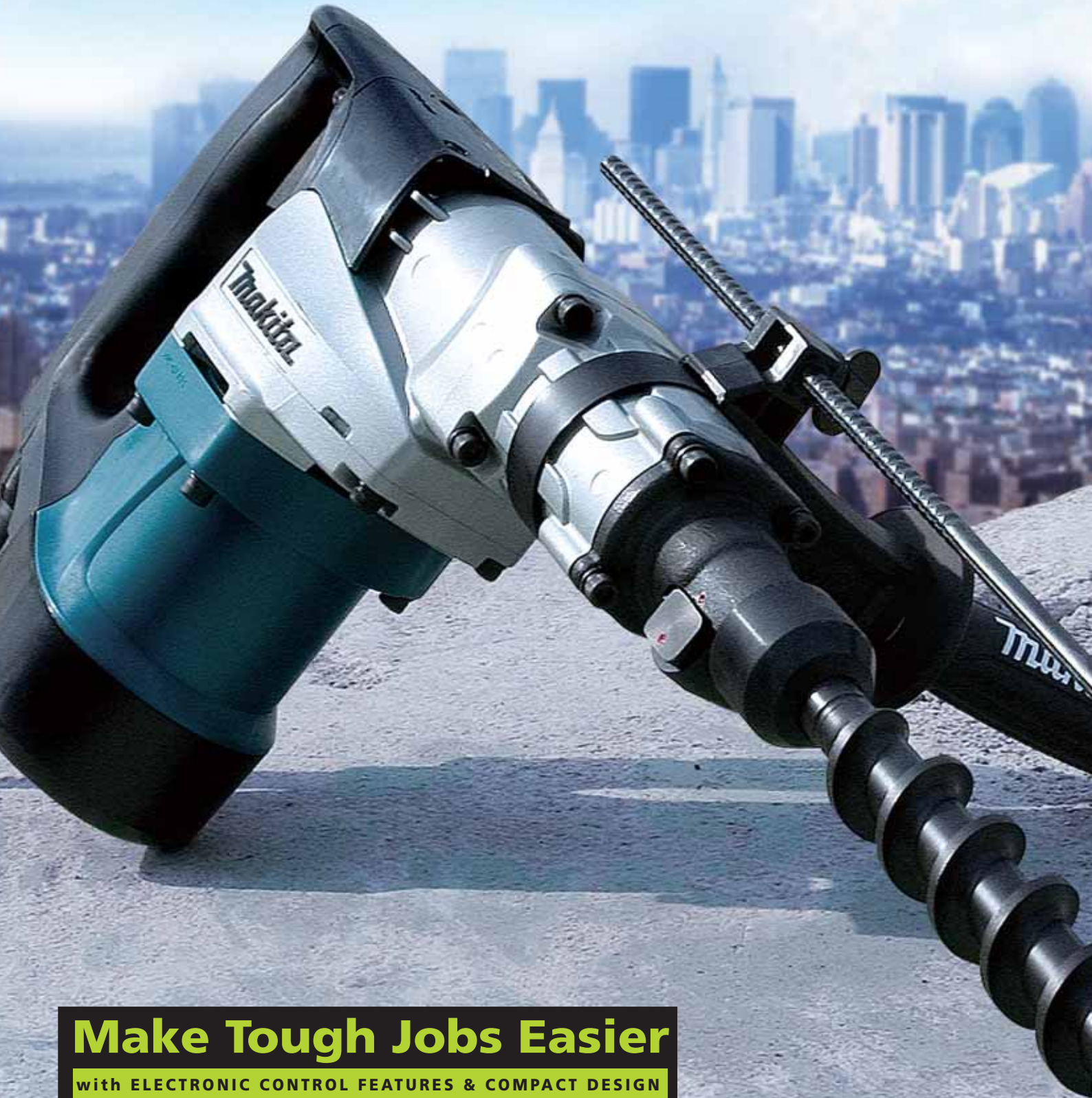

Make Tough Jobs Easier

with ELECTRONIC CONTROL FEATURES & COMPACT DESIGN



High Efficiency with Electronic Control Features

(Electronic speed control, Variable speed, Soft start)

Powerful Impact Energy: 9.2J

Lightweight: 6.2kg (13.7lbs)

Compact: 428mm (16-7/8")

247mm (9-3/4")

- Spline Shank Type**
for rotary hammering
- 3/4" Hex Shank Type**
for demolition hammering

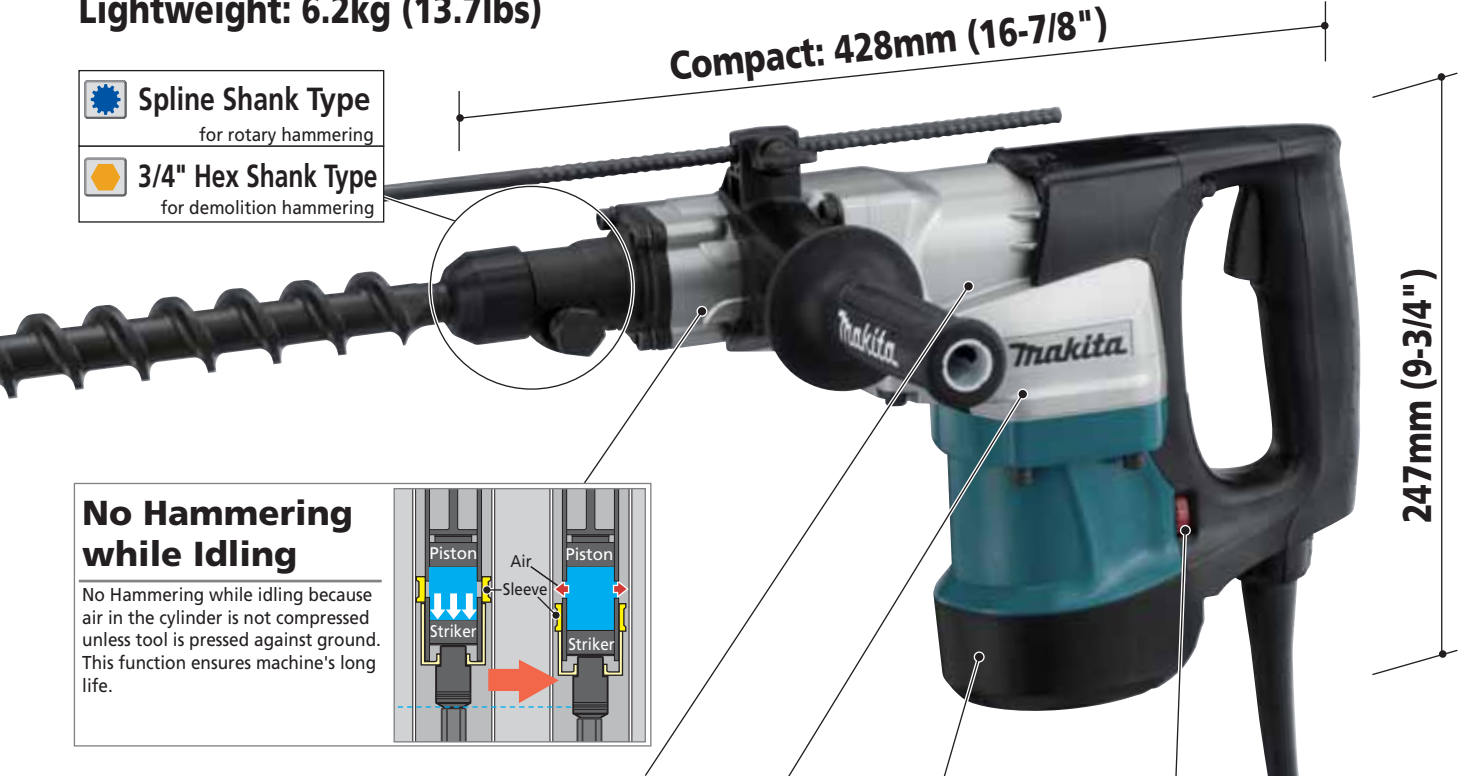

No Hammering while Idling

No Hammering while idling because air in the cylinder is not compressed unless tool is pressed against ground. This function ensures machine's long life.

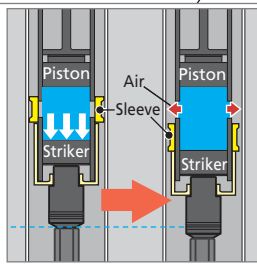

Torque Limiter

When drill bit hits against reinforcements, Torque Limiter operates to stop the rotation of drill bit, ensuring safety in your work.

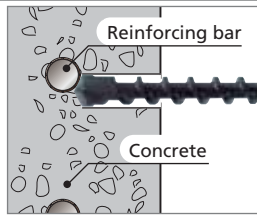

Aluminum Housing

Provides high quality and toughness

Auto Cut-Out Carbon Brush

When Carbon Brush wears out, it will automatically stop the motor. It protects commutator and indicates time for maintenance.

Dial for Electronic Speed Control

Electronic variable speed control dial enables to select speed to job.



Comparison of Efficiency

Note: 1. It may differ under some conditions.
2. Numbers in the charts below are relative values when the capacities of Competitor "H" are indexed at 100.

Test conditions: Drilled in concrete with compressive strength of 40N/mm² to a depth of 40mm.

Test conditions: Chipped concrete with compressive strength of 35N/mm², and measured the amount of concrete removed.

Drilling speed (Bit diameter: 32mm)

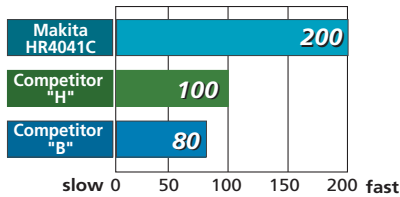

Chipping

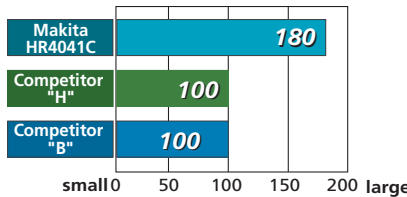

Rotary Hammer

- Double Insulation
- Electronic Speed Control
- Variable Speed
- Torque Limiter
- Soft Start
- Carrying Case



HR4041C 40mm (1-9/16")

350

Continuous rating Input	1,100W
Max. bit dia.	40mm (1-9/16")
Max. core bit dia.	118mm (4-5/8")
Blows per minute	1,300 - 2,600bpm
No load speed	230 - 460rpm
Dimensions (L x W x H)	428mm x 107mm x 247mm (16-7/8" x 4-1/4" x 9-3/4")
Net weight	6.2 kg (13.7lbs)
Power supply cord	5m (16.4ft)

Standard Equipment

Depth Gauge, Grip Assembly (Tool does not come with bit)

Standard equipment and specifications may differ by country or area.

Makita Corporation

3-11-8 Sumiyoshi-cho, Anjo, Aichi, 446-8502 Japan

PRINTED IN JAPAN Z23291-2 2007-01